

# MINIDROP

COOKIE DEPOSITOR

# MIMAC



La ultraventennale esperienza ed il costante rinnovamento tecnologico hanno collocato MIMAC ITALIA S.r.l. ai vertici del mercato mondiale nella produzione di macchine colatrici per la piccola e media pasticceria.

Un design moderno dalle linee essenziali, qualità dei materiali, lavorazioni precise e raffinate pongono il nuovo progetto della MINIDROP all'avanguardia nel settore.

Praticità di utilizzo, velocità, affidabilità elettronica e robustezza meccanica sono solo alcune delle caratteristiche che contraddistinguono il nuovo modello MINIDROP.

More than twenty years of experience and constant technological renewal have placed MIMAC ITALIA S.r.l. at the top of the world market for the production of dropping machines for the small and medium pastry-making industry.

A modern design with essential lines, quality material, combined with precise and refined working place the new MINIDROP project at the front of the sector.

Simplicity of use, speed, electronic reliability and mechanical strength are just some of the distinguishing characteristics of the new MINIDROP machine.

Son expérience de plus de vingt ans et son renouvellement technologique constant ont permis à MIMAC ITALIA S.r.l. d'occuper une position leader sur le marché mondial dans la production de machines dresseuses pour la petite et la moyenne pâtisserie.

Un design moderne aux lignes épurées, fait de matériaux de qualité, avec des usinages précis et raffinés place le nouveau projet de la MINIDROP à l'avant-garde dans le secteur.

Commodité d'utilisation, rapidité, fiabilité électronique et robustesse mécanique sont seulement quelques-uns des aspects qui caractérisent le nouveau modèle MINIDROP.

La experiencia de más de veinte años y la renovación tecnológica constante han colocado MIMAC ITALIA S.r.l. en la cumbre del mercado mundial de la producción de máquinas dosificadoras para la pastelería pequeña y mediana.

Un diseño moderno de líneas esenciales, alta calidad de los materiales, elaboraciones precisas y refinadas, que pone el nuevo proyecto de MINIDROP en la vanguardia del sector.

Practicidad de uso, velocidad, fiabilidad electrónica y solidez mecánica son solamente algunas de las características que distinguen el proyecto de la nueva MINIDROP.



# MINIDROP

## COOKIE DEPOSITOR



[www.mimac.com](http://www.mimac.com)



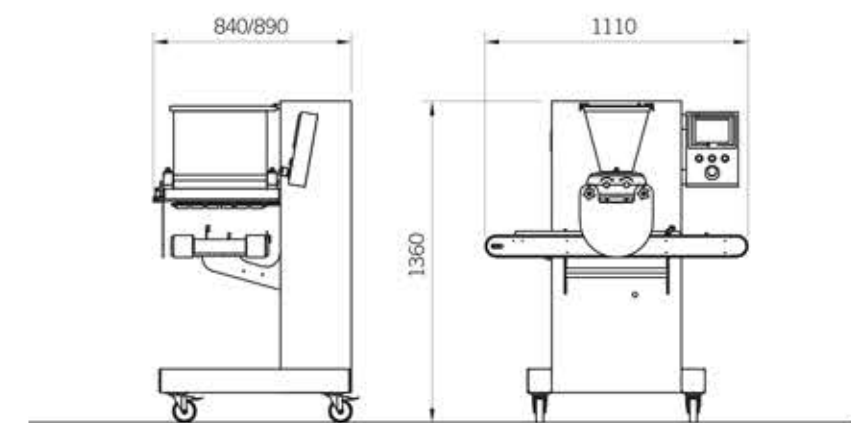

DATI TECNICI - TECHNICAL DATA DONNEES TECHNIQUES - DATOS TÉCNICOS	400	450
Capacità tramoggia - Hopper capacity - Capacité trémie - Capacidad tolva	29 lt	32 lt
Peso - Weight - Poids - Peso	270 kg	290 kg
Potenza - Power - Puissance - Potencia	1,6 kW	1,6 kW



[www.mimac.com](http://www.mimac.com)





Testata a rulli  
Roller head  
Tête à rouleaux  
Cabezal de rodillos

Oltre al gruppo di dosaggio per impasti consistenti, MINIDROP prevede la possibilità di lavorare anche con il gruppo di dosaggio a pompa per impasti fluidi e cremosi (optional).

In addition to the dosing group for hard dough, MINIDROP can also work with the pump dosing group for creamier soft dough (optional).



Testata a pompa  
Pump head  
Tête à pompe  
Cabezal de bomba

Oltre le groupe de dosage pour pâtes consistantes, MINIDROP prévoit aussi la possibilité de travailler avec le groupe de dosage à pompe pour des pâtes fluides et crémeuses (en option).

Además del grupo de dosificación para masas consistentes, MINIDROP prevé la posibilidad de trabajar también con el grupo de dosificación de bomba, para masas fluidas y cremosas (opcional).





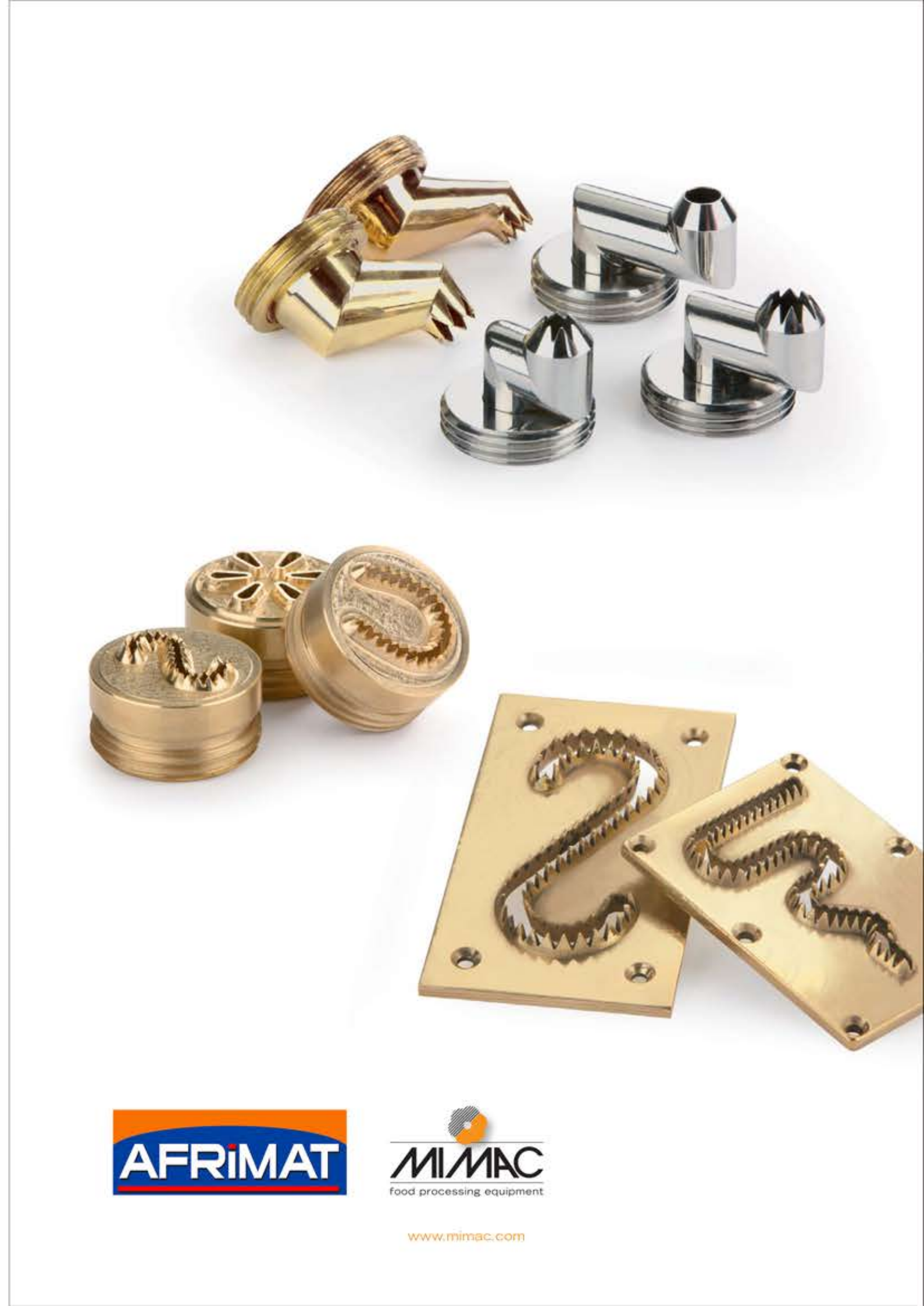

[www.mimac.com](http://www.mimac.com)



Stampo **Fisso**



Stationary mould  
Règle fixe  
Molde fijo



Stampo **Girevole**



Rotary mould  
Règle tournante  
Molde giratorio

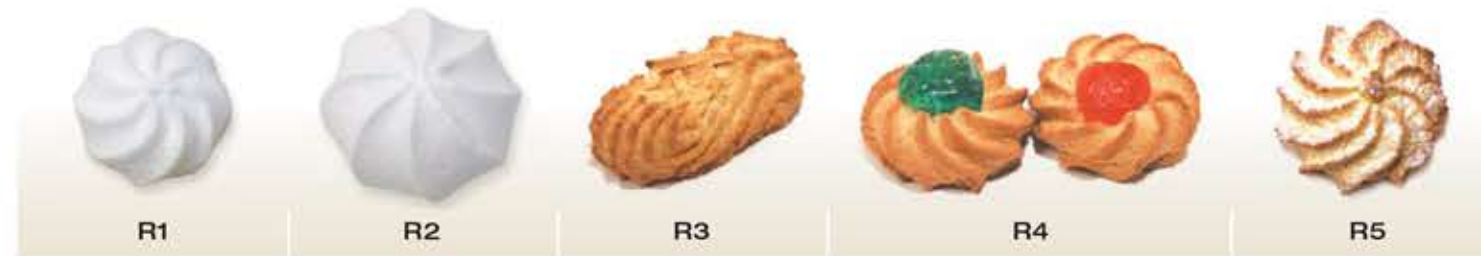

Testata a **Pompa**



Pump head  
Tête à pompe  
Cabezal de bomba

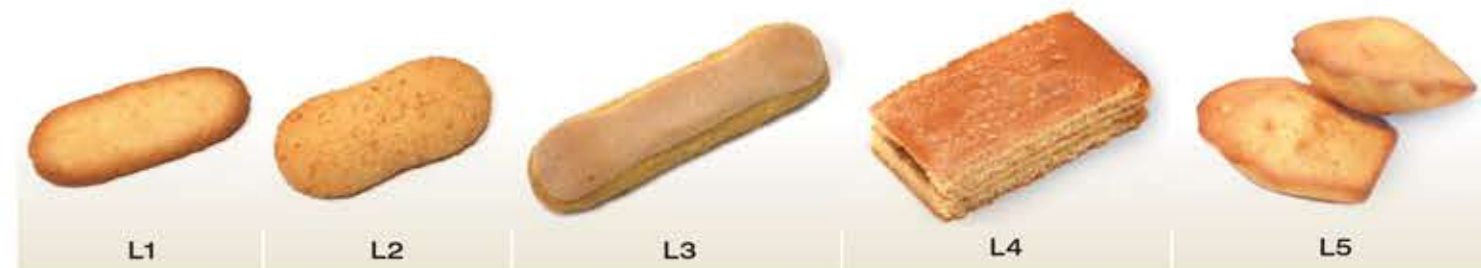



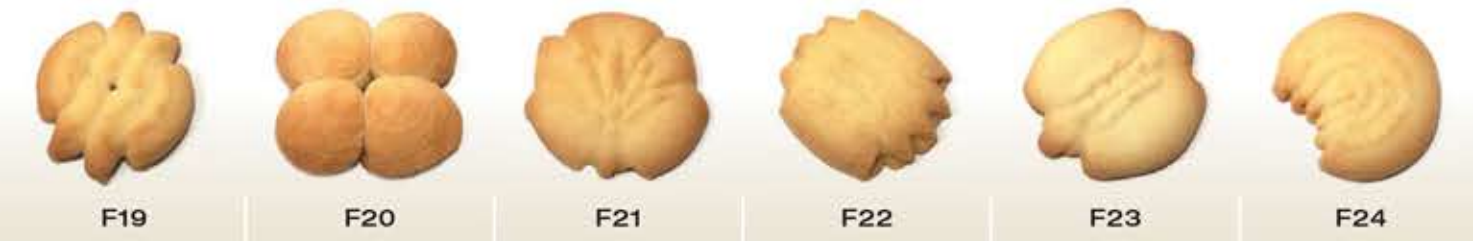
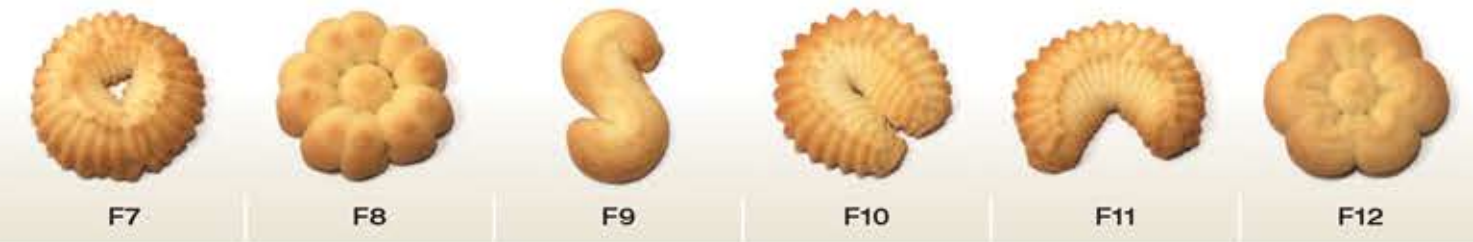
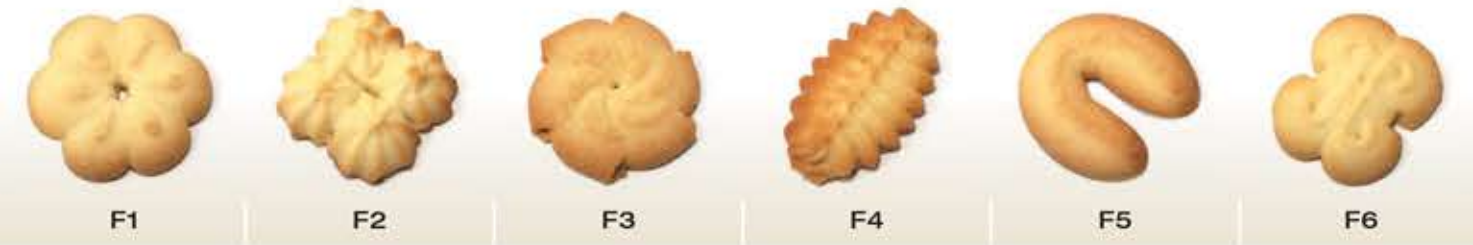

Decorazioni ed accoppiamenti sono fatti a mano. Savoiardi, plum-cake e muffin sono colati in teglie stampate.  
Topping and sandwiching are made by hand. Lady-fingers, cup cakes and muffins are deposited into moulded trays.  
Décorations et combinaisons sont faites à la main. Biscuits à la cuiller, cakes and muffins sont dosés sur plaques préformées.  
Decoraciones y uniones de productos son hechas a mano. Bizcochos de Soletilla, magdalenas y muffins son dosificados en bandejas moldeadas.







Il pannello di controllo con il suo display Touch Screen si presenta intuitivo, funzionale e di facile apprendimento.

The control panel with its Touch Screen display is intuitive, functional and very easy to use.

Le tableau de contrôle avec son écran tactile se présente intuitif, fonctionnel et d'apprentissage facile.

El cuadro de control, con su pantalla táctil se presenta intuitivo, funcional y de fácil aprendizaje.



Una vastissima gamma di bocchette e stampi consentono di realizzare i prodotti in svariate forme e dimensioni lasciando ampia creatività e fantasia all'utilizzatore.

A very wide range of nozzles and moulds allows the creation of numerous shapes and sizes, leaving wide space for the creativity and fantasy of the user.

Une très vaste gamme de douilles et de règles permettent de réaliser les produits dans de nombreuses formes et dimensions, ce qui laisse une grande créativité et une vaste imagination à l'utilisateur.

Una amplísima gama de boquillas y de moldes permiten realizar productos de muchas formas y dimensiones, dejando una amplia creatividad y fantasía al usuario.



[www.mimac.com](http://www.mimac.com)





**SPECIALISTE DU MATERIEL DE  
PRODUCTION SUCREE ET SALEE**

**CITE ENASSIM N°30  
ONAMA 2500 CONSTANTINE RION'  
TÉL\FAX: 031.62.31.23  
MOB: 07.74.38.96.32  
MAIL: AFRIMAT@HOTMAIL.FR  
WEB : WWW.AFRIMAT-DZ.COM**



**MIMAC ITALIA s.r.l.**  
Via dell'Industria, 22  
36013 PIOVENE ROCCHETTE  
Vicenza - Italy  
Tel. +39 0445 576 250  
Fax +39 0445 576 112  
www.mimac.com  
info@mimac.com

**MIMAC ITALIA S.R.L.**  
Si riserva il diritto di apportare eventuali modifiche tecniche e costruttive  
Reserves the right to make any technical and structural modification  
Se réserve le droit d'apporter éventuelles modifications et de construction  
Se reserva la facultad de aportar eventuales modificaciones técnicas y constructivas